

SOUTHWEST RESEARCH INSTITUTE™

6220 CULEBRA ROAD • POST OFFICE DRAWER 28510 • SAN ANTONIO, TEXAS, USA 78228-0510 • (210) 684-5111 • TELEX 244846

ENGINE AND VEHICLE RESEARCH DIVISION
FAX: (210) 522-5720

<http://engineandvehicle.swri.org>
ISO 9001 Certified

COMPUTER SIMULATION AND ANALYSIS OF MULTI-CONE CLUTCH DESIGN FOR THE SMARTMATIC TRANSMISSION

ABRIDGED FINAL REPORT

*This report must be
reproduced in full, unless
SwRI® approves a summary
or abridgement.*

SwRI Project No. 03-05169

Prepared for:

SELECT DESIGN TECHNOLOGIES LIMITED
53 Glenvale Crs.
Mulgrave, Vic. 3170
AUSTRALIA

Prepared by:

Brad Pohl
Research Engineer
Southwest Research Institute
Drivetrain Development
6220 Culebra Road
San Antonio, TX 78238

June 7, 2002

Reviewed:



Michael A. Kluger, Assistant Director
Drivetrain Development

Approved:



Gary L. Stecklein, Director
Vehicle Systems Research Department

D:\WorkingFiles\TerryD\05169 SELECT DESIGN abridged final report_2 bp.doc



SAN ANTONIO, TEXAS

HOUSTON, TEXAS • DETROIT, MICHIGAN • WASHINGTON, DC

ABRIDGED FINAL REPORT

This document is a summary of work that has been performed by SwRI under contract with Select Design Technologies. SwRI was contracted to evaluate the viability of the multi-cone clutch for power shift and vehicle launch applications. This evaluation was conducted by leveraging two methods, computer simulation and prototype fabrication/test. Computer simulation was focused around implementing existing theoretical understanding of clutch operation to conduct “what if” and “comparative” simulations. Prototype fabrication and test methods were implemented to provide a basis from which to judge the theoretical results. Figure 1 shows an exploded view of the design developed by SwRI and Figure 2 shows the hardware that was tested according to SAE standards. The prototype was designed with a 14° cone angle to explore this clutch design at the lowest possible cone angle that provided a critical friction coefficient sufficiently higher than the expected actual friction coefficient.

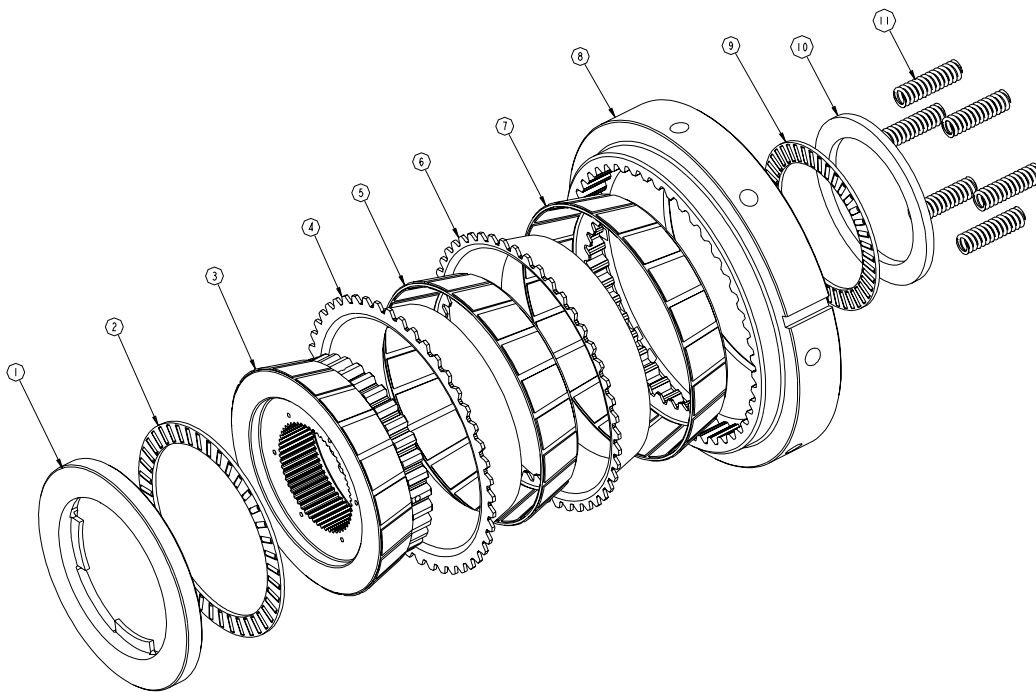

Figure 1. Prototype Cone Clutch Assembly



SAN ANTONIO, TEXAS

HOUSTON, TEXAS • DETROIT, MICHIGAN • WASHINGTON, DC

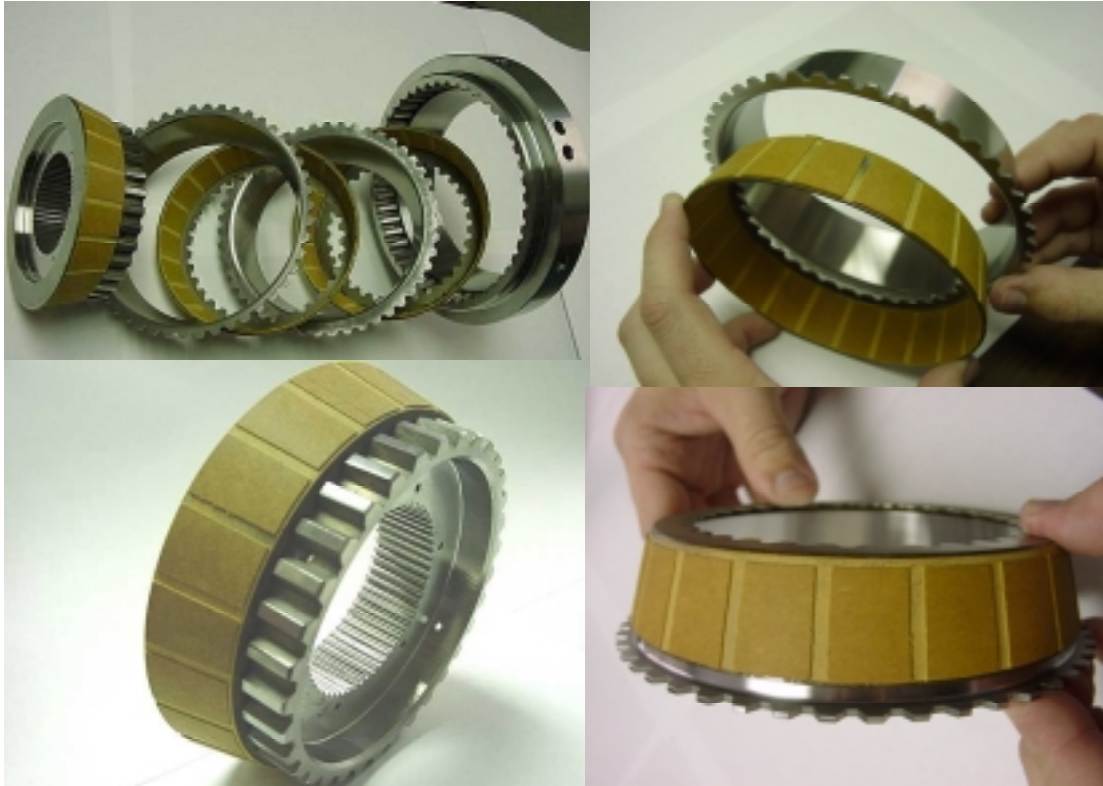

Figure 2. Completed Prototype

The use of a multi-cone clutch provides an attractive clutching solution for the requirements of the lay-shaft automated manual transmission illustrated in Select Design Technology's patents. Cone clutch technology is somewhat mature, however the use of a multi-cone version of the cone clutch concept for high-energy applications like vehicle launch and power shift is not a readily available technology. The following list describes the advantages and development areas of the cone clutch.

Advantage:

- Reduced Axial Force Requirements

Characteristics Equivalent to Existing Technology:

- Thermal Response (Surface Temperatures)
- Open Clutch Drag Loss
- Package Volume (for Low Cone Angles)



SAN ANTONIO, TEXAS

HOUSTON, TEXAS • DETROIT, MICHIGAN • WASHINGTON, DC

Development Areas:

- Axial Force Control Sensitivity
- Manufacturing Tolerances

It is very important to realize that reduced axial force requirements have far reaching implications when complete transmission design is considered. Reductions in axial force requirements allow for reduced oil pump losses or provide more flexibility in alternative clutch actuation methods.

Theoretical work accomplished in this project indicate that increases in control system sensitivity to effect proper control of the cone clutch are not out of the realm of possibility for modern control system designs employed to effect control of existing flat plate clutch designs.

The experience and information gathered from this evaluation effort indicate that the multi-plate cone clutch has merit as a power shifting or vehicle launch device. This first ever prototype was able to withstand 18,000 extremely harsh engagement cycles. This design concept will need additional development to mature a sound manufacturing method that can produce the required tolerances to effect smooth operation. Excessive torque fluctuations experienced with the prototype as shown in Figure 3 are perceived to be related to fabrication errors, primarily circular run-out. High plate temperatures recorded during prototype testing appear to be due to inadequate surface to surface contact from angularity errors.

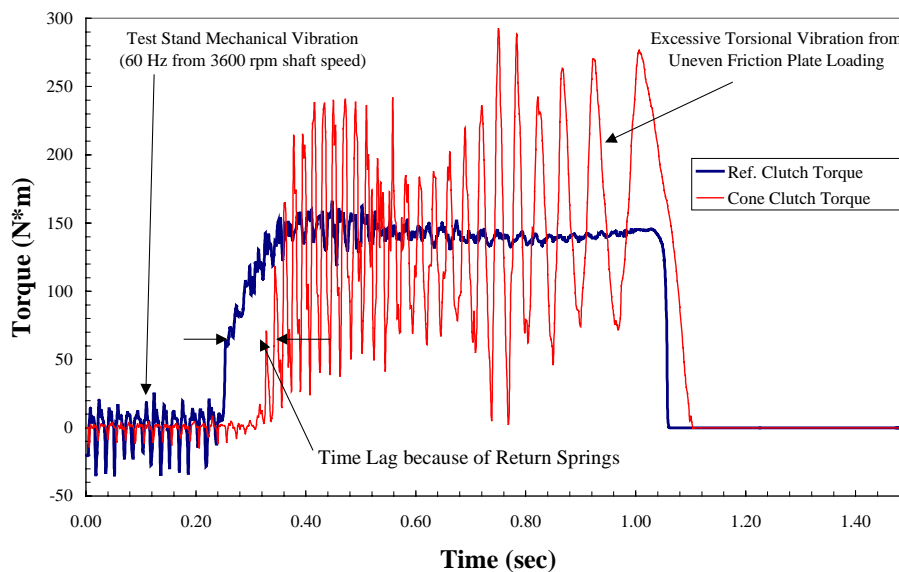

Figure 3. Prototype Torque Performance



SAN ANTONIO, TEXAS

HOUSTON, TEXAS • DETROIT, MICHIGAN • WASHINGTON, DC

The use of the multi-cone clutch technology has application in other power transmission technologies. Theoretical work indicates that existing multi-plate technology of automatic transmissions could be replaced by the cone clutch and thus provides for a direct reduction in axial force requirements. Figure 4 is a plot of the axial engagement force realized with the prototype and is compared to a similarly sized flat type clutch for reference. This axial force reduction could reduce the pressure requirements of the hydraulic pump. Oil pressure reduction leads to transmission efficiency gains as well as opens the door for cheaper pump manufacturing through reduced tolerances. The use of the multi-cone could also be extended to other areas such as improved transfer case operation in 4-wheel drive vehicles.

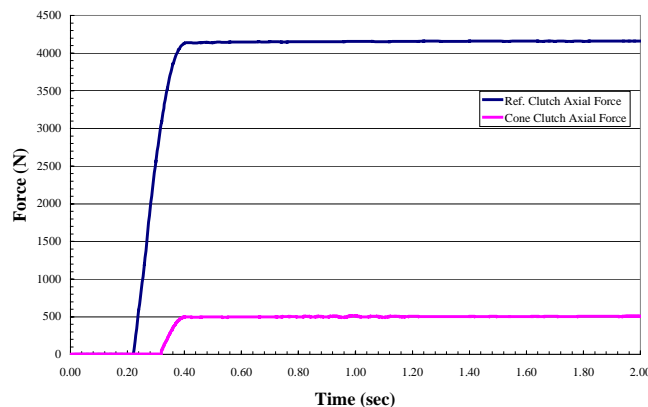

Figure 4. Clutch Axial Force

The potential of a multi-cone clutch appears to be of enough merit to warrant further pursuit of this technology. Further work with the multi-plate cone clutch should be focused on developing suitable manufacturing methods and clutch actuation control strategies. This should be accomplished through second generation prototype fabrication as well as implementation efforts to build a full scale prototype transmission in the embodiment of Select Design Technologies patent to prove-out clutch actuation control.

If you have any questions or need further information, please do not hesitate to contact me at (210) 522-3737, or fax at (210) 522-4581. My e-mail address is bpohl@swri.org.

Prepared and submitted by:

Brad Pohl, Research Engineer
Drivetrain Development
Vehicle Systems Research Department

/tyd

D:\Shared\BPohl\temp\05169 abridged final report bp.doc



SAN ANTONIO, TEXAS

HOUSTON, TEXAS • DETROIT, MICHIGAN • WASHINGTON, DC